



IMPORTANTE : INFORMACIÓN OBSOLETA
Ver en web www.guemisa.com y descargar
la nueva versión en el apartado de Novotechnik



Special features

- extremely low torque: 0.003 Ncm
- very long life - 100×10^6 movements
- excellent linearity - standard $\pm 0.1\%$ up to $\pm 0.07\%$ on request
- very good repeatability better than 0.01°
- single integrated main bearing
- shaft with screwdriver slot and marking
- unrestricted continuous rotation

The distinctive features of conductive plastic potentiometers are a single integrated main bearing with very close tolerances and shaft with screw-driver slot combined with a shaft marking for easy identification of the wiper position. Because of its extremely low torque, this potentiometer is particularly suitable for applications where the repercussions of the driving shaft could lead to measuring faults.

The standard version P2201 A502 has a nominal resistance of 5 k Ω .

Special versions with different electrical travels are available.

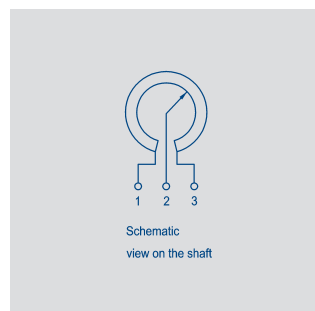
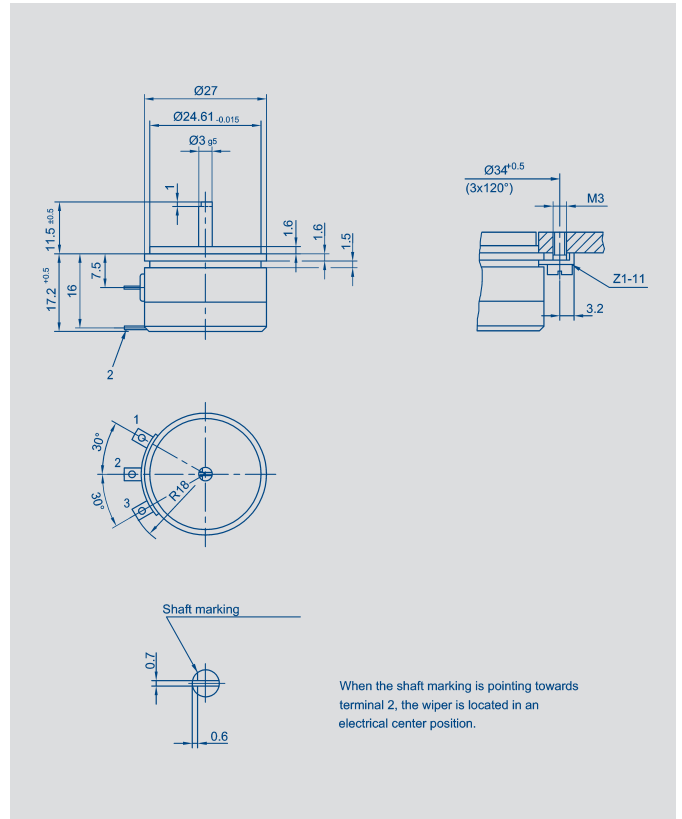

Sta. Virgilia 29 Local.1A 28033 Madrid
Tfno.: 91 764 21 00 Fax.: 91 764 21 32
www.guemisa.com Email.: info@guemisa.com

Description

Size	servo size 11
Case	anodized aluminium, cover plastic
Shaft	stainless steel with screwdriver slot and marking
Bearings	stainless integrated steel ball bearings, dust-protected
Resistance element	conductive plastic
Wiper assembly	precious metal multi-finger wipers
Electrical connections	terminals gold-plated brass

Mechanical Data		
Dimensions	see drawing	
Mounting	with 3 clamps Z 1 - 11	
Mechanical travel	360, continuous	°
Permitted shaft loading (axial and radial) static or dynamic force	15	N
Maximum torque	≤0.003	Ncm
Maximum operational speed	600	min ⁻¹
Weight	20	g

Electrical Data		
Actual electrical travel	345 ±2	°
Nominal resistance	5	kΩ
Resistance tolerance	±20	%
Repeatability	0.0012 (Δ 0.004°)	%
Effective temperature coefficient of the output-to-applied voltage ratio	typical 5	ppm/K
Independent linearity	±0.1	%
Max. permissible applied voltage	42	V
Recommended operating wiper current	≤ 1	μA
Max. wiper current in case of malfunction	10	mA
Insulation resistance (500 VDC, 1 bar, 2 s)	≥ 10	MΩ
Dielectric strength (50 Hz, 2 s, 1 bar, 500 VAC)	≤ 100	μA

Environmental Data		
Temperature range	-40...+100	°C
Vibration	5...2000 A _{max} = 0.75 a _{max} = 5	Hz mm g
Shock	10 11	g ms
Life	100 x 10 ⁶	movem.
Protection class	IP 50 (DIN 400 50 / IEC 529)	

Order designations	
Type	Art.no.
P2201 A502	014203

Type designations for non-standard models will be specified upon receipt of order.

Included in delivery

3 clamps Z1-11

Recommended accessories

Fork coupling Z 103 G 3
(backlash free),
Process-controlled indicators
MAP... with display,
Signal conditioner MUP.../
MUK ... for standardized
output signals

Important

All the values given in this data sheet for linearity, lifetime and temperature coefficient in the voltage dividing mode are quoted for the device operating with the wiper voltage driving on operational amplifier working as a voltage follower, where virtually no load is applied to the wiper ($I_{\theta} \leq 1 \mu\text{A}$).