



SENSORES DE PAR DINÁMICO SERIE 2000



- Measurement range 2.5 up to 500 Nm bidirectional
- Repeatability $\leq \pm 0.1\%$
- Analog signal output 0.5V...4.5V
- Maintenance free operation
- Torque measurements at up to 5000rpm
- Contactless measurement
- Bandwidth 1kHz
- Integrated signal conditioning

1. Introduction

Los sensores de par dinámico de la serie 2000, han sido diseñados para medir par bidireccional tanto estático como dinámico en tiempo real. El sistema de medida es sin contacto entre el eje y el cuerpo del sensor, consiguiendo un equipo sin mantenimiento y de una alta fiabilidad, en el interior de la carcasa se encuentra la electrónica de detección y el amplificador. El conjunto se caracteriza por un bajo consumo, precisión, larga estabilidad de la medida en el tiempo y una excelente relación calidad - precio.



2. Characteristics

Model No. 2x00, (TM-HR-X V06)		Max rated Torque [Nm (ft-lb)]	Max Overload [Nm (ft-lb)]	Max Rotational [rpm]
Round (Rd) Drive	Square (Sq) Drive	bidirectional (+/-)	bidirectional (+/-)	Rd/Sq
2200-2.5 (TM-HR-Rd-2.5 V06)	2100-2.5 (TM-HR-Sq-2.5 V06)	2.5 (1.8)	5 (3.6)	5000 / 1000
2200-5.0 (TM-HR-Rd-5.0 V06)	2100-5.0 (TM-HR-Sq-5.0 V06)	5.0 (3.7)	10 (7.4)	5000 / 1000
2200-7.5 (TM-HR-Rd-7.5 V06)	2100-7.5 (TM-HR-Sq-7.5 V06)	7.5 (5.5)	15 (11)	5000 / 1000
2200-17.5 (TM-HR-Rd-17.5 V06)	2100-17.5 (TM-HR-Sq-17.5 V06)	17,5 (12.9)	35 (25.8)	5000 / 1000
2200-75 (TM-HR-Rd-75 V06)	2100-75 (TM-HR-Sq-75 V06)	75 (55.3)	150 (110.6)	5000 / 1000
2200-175 (TM-HR-Rd-175 V06)	2100-175 (TM-HR-Sq-175 V06)	175 (129)	350 (258)	5000 / 1000
2200-250 (TM-HR-Rd-250.0 V06)	2100-250 (TM-HR-Sq-250 V06)	250 (184.3)	350 (258)	5000 / 1000
	2100-500 (TM-HR-Sq-500 V07)	500 (368.6)	750 (552.9)	1000

3. Technical Features

Description	Symbol									Unit	Remarks
		2x00-2.5 (TM-HR)	2x00-5.0 (TM-HR)	2x00-7.5 (TM-HR)	2x00-17.5 (TM-HR)	2x00-75 (TM-HR)	2x00-175 (TM-HR)	2x00-250 (TM-HR)	2x00-500 (TM-HR)		
Maximum rated torque - bi-directional	M	2.5	5.0	7.5	17.5	75	175	250	500	Nm	Full Scale (FS) = 0 to maximum rated torque
Analog signal output	V _{out}	0.5 - 4.5								VDC	
Degree of protection		IP 50								Per EN60529	
Supply voltage	V _{cc}	9.0 ..12.0								VDC	
Current consumption	I _{in}	< 10 (Startpeak: 60mA for 10ms)								mA	
Signal output at 0 Nm (adj. via offset Pot.)	V _{out(0)}	2.5								V	Adjustable via potentiometer
Signal output resistance		50									
Signal bandwidth	BW	1000								Hz	
Rotational speed (Rd or 2200: round shaft Sq or 2100: square shaft)	n	0 ... 5000								rpm	
		0 ... 1000									
Repeatability		<±0.1								%FS	DKD-R 3-5
Hysteresis and linearity failure and signal variation during rotation		<1								%FS	
		<2									
Operating temperature range	T _{op}	0 ... +70								°C	Reference temperature: 21°C
Maximum longitudinal force between shaft and housing	F _l	40								N	Influence on meas. signal <1%FS
Maximal lateral force	F _q	50								N	Influence on meas. signal <1%FS
Zero drift (temperature-related)		< ±0.1								%FS/ K	
Resistance to magnetic fields (distance 70mm)		4000								Oe	Minimal distance from sensor housing: 70mm
		318								kA/m	
Electromagnetic compatibility											EN 55011, EN 6100-4-3, EN 6100-4-6, EN 6100-4-4, EN 6100-4-2, EN 50204, EN 50081-3, EN 50082-2. Not intended for medical use
Storage temperature	T	-20...+100								°C	
Weight	Round	383	386	392	400	685	856	861	XX		
	Square	395	397	401	386	652	754	749	1385		

4. Typical Sensor Output

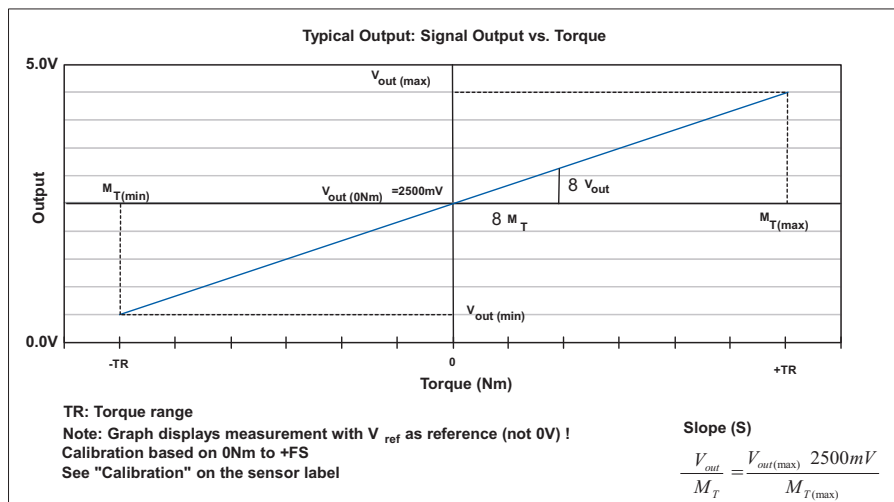

Sensor Label Example

ROTARY TORQUE SENSOR

Model: 2100-76

Part No. 11150601/Rev. 1

Serial No. A110927460

Calibration 15.57 mV/Nm (21.11 mV/lb-ft)

Nominal Torque Range (bi-directional) 0 to 25 Nm (0 to 55 lb-ft)

Maximum Overload 150 Nm (111 lb-ft)

Degree of Protection IP 50

Supply Voltage V_{cc} 9 - 12 V

Signal output at 0 Nm (adjustable) 2.5 V

Nominal Current I_n 4.8 - 8.8 mA

Read instructions before first use! Do not open!
 Proximity of magnetic fields can generate measurement errors and permanently damage the sensor!

V_{out(max)} and V_{out(min)} are defined by the slope of each sensor. This means, the output is capable to be between 0.5V and 4.5V; the actual signal output range depends on the calibration value and the torque range.

5. Mechanical features

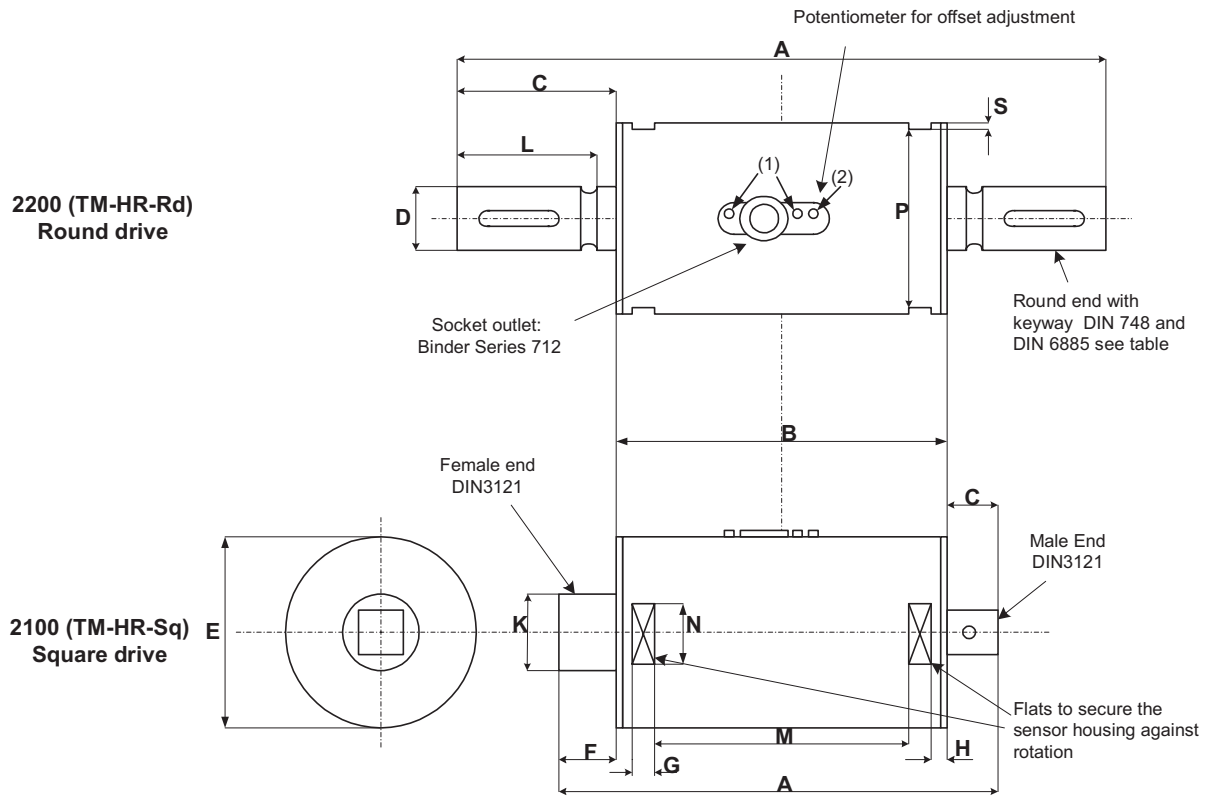

- (1) Do not loosen or thighten the assembly screws
- (2) See 8.4 – Offset adjustment

Dimensions	Nominal Torque Capacity [Nm]	A	B	C	D	E	F	G	H	K	L	M	N	P	S
Square drive shaft (2100)															
1/4 Inch	2.5 - 5.0 - 7.5 - 17.5	95.5	70	9.5	-	40	16	8	5	12	-	43.9	15	37	1.5
3/8 Inch	75	107	70	13	-	50	24	8	5	18	-	43.9	18	47	1.5
1/2 Inch	175 - 250	123.5	70	18.5	-	50	35	8	5	24	-	43.9	18	47	1.5
3/4 Inch	500	146	87	29.6	-	60	29.6	10.5	2	33.5	-	61.4	19	57	1.5
Round drive shaft (2200)															
Ø9 mm	2.5 - 5.0 - 7.5 - 17.5	125	70	27.5	9	40	-	8	5	-	23	43.9	15	37	1.5
Ø 14 mm	75	139	70	34.5	14	50	-	8	5	-	30	43.9	18	47	1.5
Ø 19 mm	175 - 250	179	70	54.5	19	50	-	8	5	-	50	43.9	18	47	1.5

Dimensions Keyway [mm]				Keystones	
Round drive shaft	Width	Depth	Length	Height	Length
Ø9 mm	3	1.8	18.5	3	18
Ø 14 mm	5	3	25.5	5	25
Ø 19 mm	6	3.5	45.5	6	45

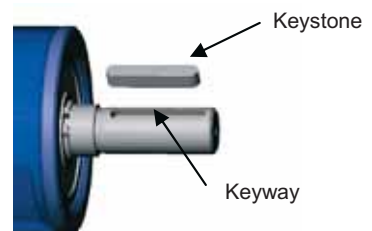

6. Terminal Diagram

Terminal diagram of socket outlet
View looking at sensor socket

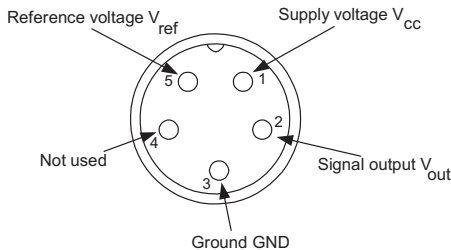

Pin	Colour	Description
1	White	Supply Voltage Vcc
2	Brown	Signal Output Vout
3	Black	Ground
4	Blue	(Not used)
5	Grey	Reference Voltage 2.5V

The output V_{ref} is a constant 2.5V output and represents the virtual zero point for direct +/- torque measurement (See below "Sensor cable connection" section B).

Use connector with proper shielding termination (360 deg). Otherwise maintain shield as close to cable ends as possible and connect to earth ground.

Sensor cable connection

- A) This circuit is recommended for **absolute** torque measurement
e.g. 2.5V equals to approx. 0 Nm.

Grey and blue wires are not in use.

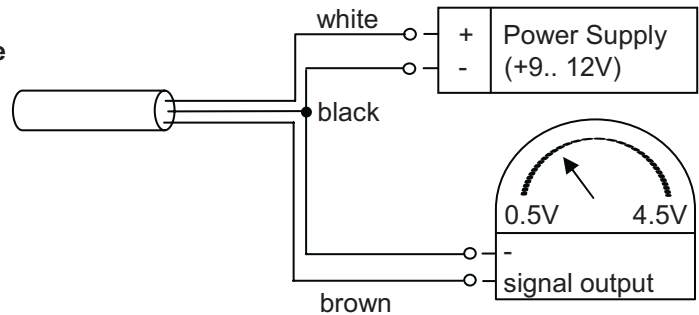

- B) This circuit is recommended for **relative** torque measurement
e. g. 0 V equals to approx. 0 Nm.

Blue wire is not in use.

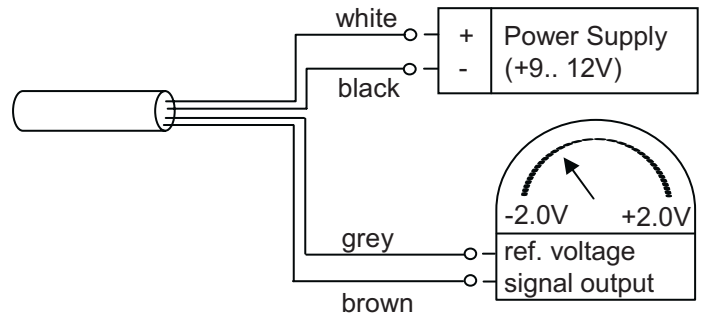

7. Accessories

- **Connection cable**, 5-pole 1,5m and 3m
(1 1,5m cable included in set)
- **Sensor- Holder**
- **Series 9100 Readout** for automatical read out with digital display of measurements. Interface options for a PC or notebook, RS232 and more features available.
- **Series 9400 Readout** for automatical read out of measurements with a PC or notebook including TorqueMeter Windows software.
- **Keystones**
(for round shafts 1 pair included in set)

Series 9100 Readout



Series 9400 Readout



8. Operating instructions

8.1 Field of Application

The torque sensor is intended for use in an industrial environment (e. g. in test stands).

8.2 Scope of Delivery

The torque sensor set consists of the sensor unit (signal detector head and signal conditioning electronics integrated into sensor housing), one connecting cable (length: 1.5 m) with a soldered-on plug connector, and one installation and instruction manual.

8.3 Sensor Installation and Removal

The shafts connected to the torque sensor must be properly aligned. A shaft coupling should be selected to eliminate or minimize backlash, angular misalignment of the shafts, end-float, or other mechanical situations that would affect the performance or operation of the torque sensor. Secure the sensor utilizing the 8mm guides on the sensor body (optional sensor holder). A maximum cable length of 3m must not be exceeded. Using a cable or connector other than supplied, or a similar cable that is of a different length may affect the overall performance of the sensor.

Prior to removing the sensor from operation, remove all lateral forces or torque stored in the mechanical assembly. Remove the keys from the shafts before loosening the mounting screws.

DO NOT REMOVE THE SHAFT WITH TORQUE APPLIED TO THE SENSOR.

8.4 Offset Adjustment

The sensor is preset at the factory setting to have an output signal at 0 Nm of 2.5 V. If required, the output signal can be adjusted via a potentiometer (2) (see 5. - Mechanical Dimensions). Remove the headless screw, set the potentiometer to 2.5 V using a plastic screwdriver. Replace the headless screw until flush with the surface of the housing.

Factory setting is 2.5V.

8.5 Interface description

Mechanical interface:

For transmission on both ends of the shafts are keyway adapter or square ends (male/female) available.

Electrical interface:

On the sensor outside is a 5 pole plug for power supply and signal lines (see 6. Terminal diagram).

8.6 Operation (Normal, Optimisation)

For optimal measurement results, do not exceed the rated torque when using the sensor. Do not operate the sensor at the maximum rotational speed for extended periods of time. Observe the prescribed operating conditions to ensure trouble-free and maintenance-free operation of the sensor.

8.7 Operation Outside Specified Conditions, Corrective Action

External magnetic fields may have an adverse effect on the measurement results. Excessive mechanical stress on the sensor (e. g. longitudinal forces / loads outside the specified limits, strong vibrations) may cause damage to the sensor and thus lead to incorrect signal outputs. Should these conditions be experienced readjusting the sensor may improve the performance (see 8.4 - Offset Adjustment). If the problem persists, do not open the sensor housing. Contact the manufacturer for assistance.

8.8 Commissioning

After sensor installation, observe the following procedure:

- Switch on the power supply unit and check the supply voltage. Peak voltages to the sensor must be avoided! Be sure to verify the power supply voltage prior to connecting the sensor!
- Using the supplied sensor cable, connect the sensor to the power supply unit.
- Connect the sensor output to a high-resistance device such as an A/D converter, oscilloscope, PLC analogue board, PC measurement board, etc.
- With the sensor under no mechanical load (zero torque condition) determine the output signal voltage.
- If required: Adjust the signal output to read 2.5V (0 Nm); see 8.4 - Offset Adjustment.

8.9 Service and Maintenance

Service Hotline:

Phone: 0034 17642100

Fax: 0034 1 7642132

There are no required maintenance operations for the sensor.

8.10 Disposal

Please return the device to the manufacturer for disposal.

8.11 Handling and Transportation

During sensor handling, storage and transportation, it is important to ensure that the sensor is not exposed to any magnetic or electromagnetic fields higher than specified by the electromagnetic compatibility. Static or dynamic loads on the sensor must be avoided.

8.12 Safety Precautions

1. Do not open the sensor housing under any circumstances.
2. Do not remove or loosen the locating rings on the shaft ends.
3. Do not loosen or tighten the nut of the flange-mounting socket-connector (1) (see 5. Mechanical dimensions). Carrying out any of the above operations (1.-3.) results in loss of sensor calibration. The sensor does no longer operate regularly and must be returned to FAST for calibration and certification.
4. Use only power supplies that are properly isolated from the electrical mains.
5. Observe the specifications regarding maximum electrical and mechanical loads on the sensor, as shown on the sensor label and under 3 - Technical Features.
6. Protect the sensor from exposure to any electric or magnetic fields higher than specified by the electromagnetic compatibility.

The three main modules of an NC sensor

NC sensing system consists of three main building blocks (or modules): the **Primary Sensor**, the **Secondary Sensor**, and the **SCSP** (Signal Conditioning & Signal Processing) electronics.

The **Primary Sensor** is a magnetically encoded region at the power transmitting shaft. The encoding process is performed “one” time only (before the final assembly of the power transmitting shaft) and is permanent. The power transmitting shaft is also called Sensor Host (or **SH**) and has to be manufactured from ferro magnetic material. In general, industrial steels that include around >1.5% to <8% Ni will be a good basis for the NC sensor system. The Primary Sensor converts the changes of the physical stresses applied to the SH into changes of the magnetic signature that can be detected at the surface of the magnetically encoded region. The SH can be solid or hollow.

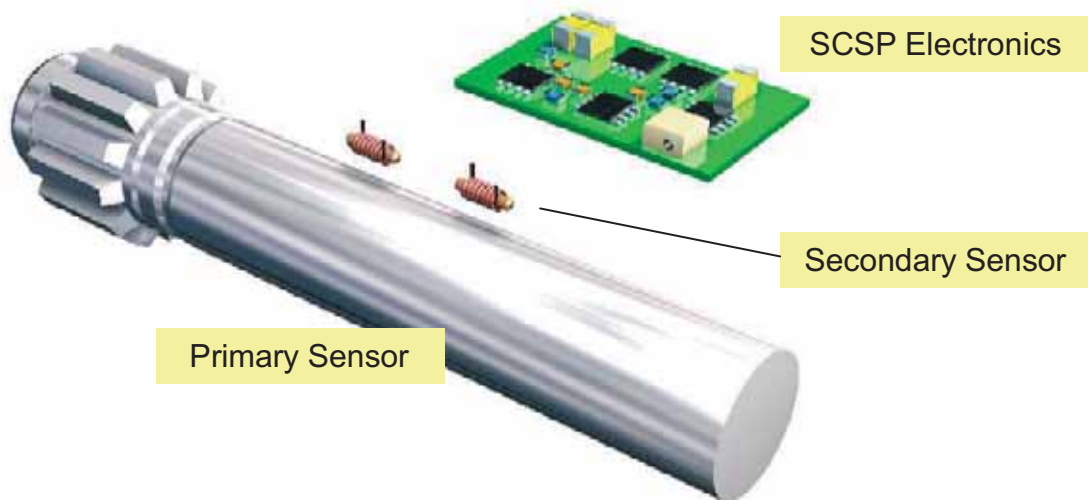

The **Secondary Sensor** is a number of Magnetic Field Sensor (**MFS**) devices that are placed nearest to the magnetically encoded region of the SH. However, the MFS devices do not need to touch the SH so that the SH can rotate freely in any direction. The Secondary Sensor converts changes of the magnetic field (caused by the Primary Sensor) into electrical information. NC is using passive MFS devices (coils) as they can be used in harsh environment (for example in oil) and operates in a very wide temperature range.

The **SCSP** (Signal Conditioning & Signal Processing) electronics drives the MFS coils and provides the user with a standard format signal output. The SCSP electronics will be connected through a twisted pair cable (2 wires only) to the MFS coils and can be placed up to 2 meters away from the MFS coils. The SCSP electronics from NC is custom designed and has a typical current consumption of 6 mA.

