

## Torque measurement of valves

### 1. Application

In many hazardous process of power generation systems it is vital to know that control valves will operate successfully when required. Monitoring of start, stop and run torque provides a reliable, non-invasive means of determining valve health and performance.

#### Installation:

Easily installed between the valve motor drive and valve drive shaft without modifications to existing equipment.

### 2. Features

- Strain gauge enclosed and protected against overload
- Built-in amplifier with current 4-20mA output
- High accuracy
- Operation temperature to 100°C
- Flanges couplings DIN 3210 or ISO 5210
- Installation without constructional changes possible
- Protected to IP 54
- Rust-resistant

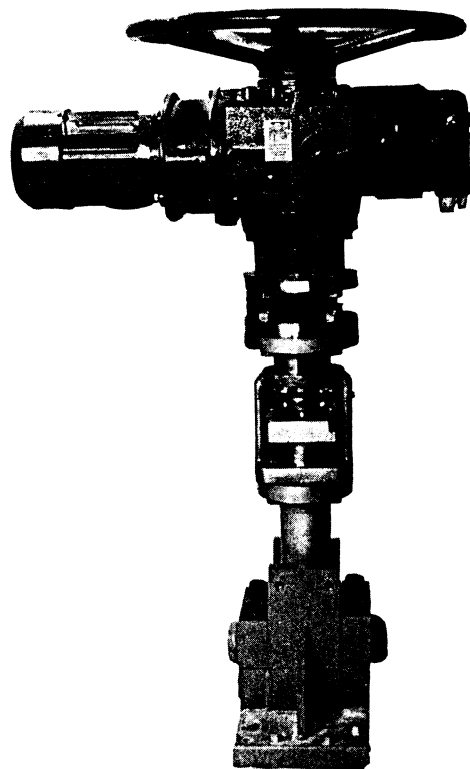

Valves test construction

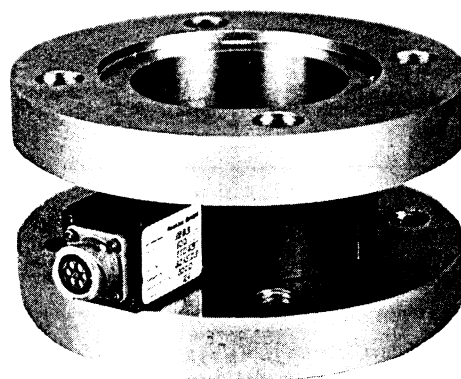

Torque measuring system

02.90

Reactional torque transducer

0153/01

### 3. Mechanical dimensions of connections

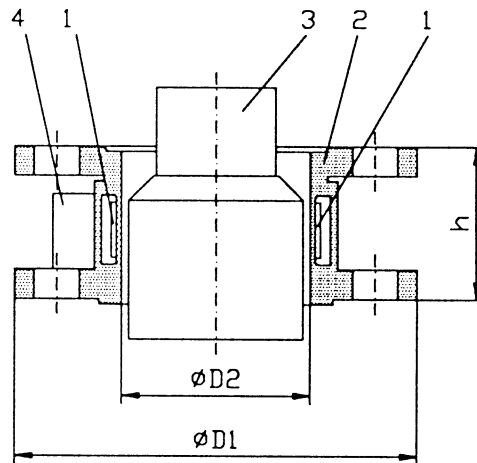

- 1 Strain gauge
- 2 Torsional socket
- 3 Adapter
- 4 Amplifier

Rated torque in Nm	Flange ISO 5210	Flange DIN 3210 size	D1	D2	h	Mass kg approx.	max. Mass of drive in kg
120	F10	0	125	54	70	2,7	35
500	F14	1/2	175	84	88	6,6	76
1000	F16	3	210	100	110	12,6	142
2000	F25	4	300	130	125	31,5	309
4000	F30	5	350	150	145	43,2	373

### 4. Technical specifications

Power Supply	24V-
Rated temperature range (continuous operation)	0°C to 60°C
max. operation temperature range	0°C to 100°C
Current output	4 to 20mA
100% cw-torque in valves	4mA
Without torque	12mA
100% ccw-torque in valves	20mA
electrical calibration	20mA
Load resistance	0 to 600 Ohm
Limit frequency	20Hz
Limit errors	± 1% of full scale
Overloadability	1,5 times rated torque
max. permissible relative humidity of surrounding air	80%



Sta. Virgilia 29 Local.1A 28033 Madrid  
 Tfno.: 91 764 21 00 Fax.: 91 764 21 32  
 www.guemisa.com Email.:info@guemisa.com