

Both shaft ends with feather key slots (2x180°) to DIN 6885 sheet 1

Size	Rated torque in Nm	A	B	C	Ø D1 g6	Ø D2 g6	E	F	G	H	J	K	L	M	N	O
01	5	35	15	29	30	16	150	170	11	207	15	115	210	112	100	130
	10		15			16										
	20		15			16										
	50		27			25										
	100		27			25										
	200		35			30										
02	50	68	35	67	50	30	150	170	11	217	18	125	232	112	100	150
	100		35			30										
	200		35			30										
	500		48			38										
	1000		68			50										
03	200	116	35	110	85	30	172	200	13	295	25	150	266	160	100	210
	500		68			50										
	1000		68			50										
	2000		85			60										
	5000		116			85										

Example of order specification for basic unit:

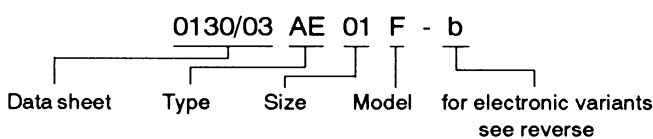

Example of order specification for exchangeable strain gauge element:

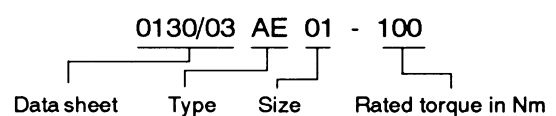

07.94	Torque transducer with exchangeable strain gauge element Type AE, Model F	0130/03
--------------	--	----------------

Features

- One basic unit with different size, instantly exchangeable gauge elements
- Especially suitable for dynamical measurement
- Simple 50 Hz power supply
- Strain gauge system
- Frequency-modulated data transmission:
 - no maintenance
 - intensive to noise
- Highest accuracy
- Built-in signal amplifier

Electrical design

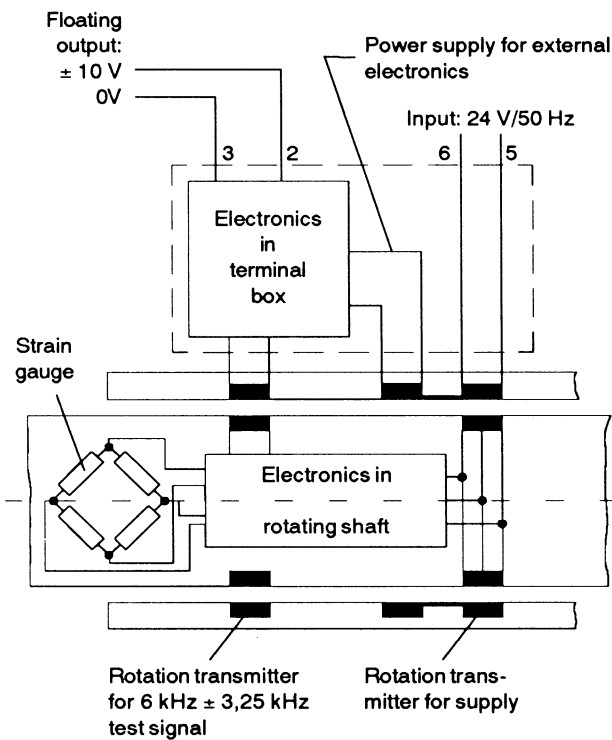

Mechanical design

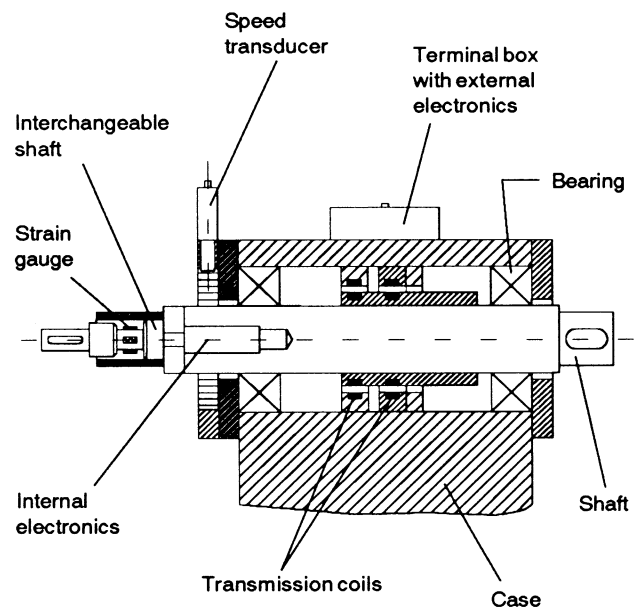

Pin connection

Suggested installation

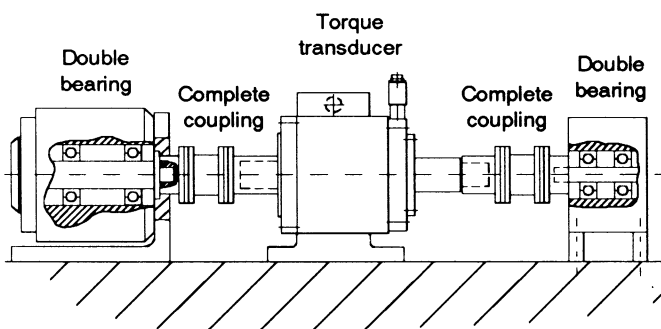

Torque	
1	free
2	$\pm 10\text{ V}$
3	0 V
4	free
5	24 ... 36 VAC
6	
7	free

Speed	
1	0 V
2	Pulses output ca. 5,5 V
3	0 V
4	+ 6 VDC ... + 10 VDC

Application Data

Electronic variants	a	b
Error limit (linearity and hysteresis)	0,1 % of full scale	0,2 % of full scale
Sensitivity deviation	≤ 0,1 % of full scale	≤ 0,2 % of full scale
Critical frequency	typically 600 Hz	
Signal rise rate 10 % - 90 % t _r	typically 0,6 ms	
Interference voltage, rms	≤ 0,1 %	
Resolution	≤ 0,02 % of full scale	
Zero drift	≤ 0,1 % of full scale	
Sensitivity	± 10 V / Rated torque at ≥ 10 kΩ	
Reference temperature	23 °C	
Rated temperature	10 ... 60 °C	
Operating temperature	0 ... 60 °C	
Shelf temperature	-30 ... + 80 °C	
Temperature influence on		
Zero TK ₀	≤ 5 · 10 ⁻⁴ (10 K) ⁻¹	
Sensitivity TK _c	≤ 1 · 10 ⁻³ (10 K) ⁻¹	
System: Strain gauge full bridge	with 700 Ω	
Supply voltage	24 V AC 10 %, 50 ... 60 Hz	

Physical Data

Torque transducer cable terminal	Type 09 - 0027 - 09 - 07, (Binder)
Speed transducer cable terminal	Type 09 - 0011 - 09 - 04, (Binder)
Overload capacity	1,5 x rated torque
Alternating load, max.	0,7 x rated torque
Rupture moment	better than 4 x rated torque
Balancing class to VDI 2060	Q = 2,5
Protection to DIN 40050	IP 40
Bearing life L _n 10	20 000 h
Colour of transducer housing	black
Speed transducer	see data sheet 3101

Rated torque in Nm	Exchangeable gauge element				Basic unit		
	Mass m in kg	Spring rate c _M in Nm/rad	Moment of inertia θ _z in kgm ²		Mass m in kg	Spring rate c _M in Nm/rad	Moment of inertia θ _z in kgm ²
			Drive side	Test side			
5	0,69	1 x 10 ³	2,7 x 10 ⁻⁴	6 x 10 ⁻⁶	11,7	1 x 10 ⁵	1 x 10 ⁻³
10	0,69	2 x 10 ³	2,7 x 10 ⁻⁴	6,4 x 10 ⁻⁶			
20	0,69	4,5 x 10 ³	2,7 x 10 ⁻⁴	7 x 10 ⁻⁶			
50	0,76	1,5 x 10 ⁴	2,7 x 10 ⁻⁴	9 x 10 ⁻⁶			
100	0,81	3,7 x 10 ⁴	2,7 x 10 ⁻⁴	1,4 x 10 ⁻⁵			
200	0,88	9,5 x 10 ⁴	2,3 x 10 ⁻⁴	4,2 x 10 ⁻⁵			
50	1,76	1,3 x 10 ⁴	6,7 x 10 ⁻⁴	9,2 x 10 ⁻⁶	19,0	5,4 x 10 ⁵	4,7 x 10 ⁻³
100	1,76	2,7 x 10 ⁴	6,9 x 10 ⁻⁴	1,7 x 10 ⁻⁵			
200	1,88	6,9 x 10 ⁴	8,3 x 10 ⁻⁴	1,1 x 10 ⁻⁴			
500	2,16	1,1 x 10 ⁵	7,0 x 10 ⁻⁴	1,4 x 10 ⁻⁴			
1000	2,67	3,7 x 10 ⁵	8,1 x 10 ⁻⁴	4,1 x 10 ⁻⁴	45,5	2,7 x 10 ⁶	3,0 x 10 ⁻²
200	4,58	5,6 x 10 ⁴	3,0 x 10 ⁻³	4,1 x 10 ⁻⁵			
500	5,30	1,4 x 10 ⁵	3,0 x 10 ⁻³	1,2 x 10 ⁻⁴			
1000	5,50	2,7 x 10 ⁵	3,6 x 10 ⁻³	5,8 x 10 ⁻⁴			
2000	6,30	5,9 x 10 ⁵	3,6 x 10 ⁻³	1,6 x 10 ⁻³			
5000	9,60	1,6 x 10 ⁶	4,1 x 10 ⁻³	5,7 x 10 ⁻³			

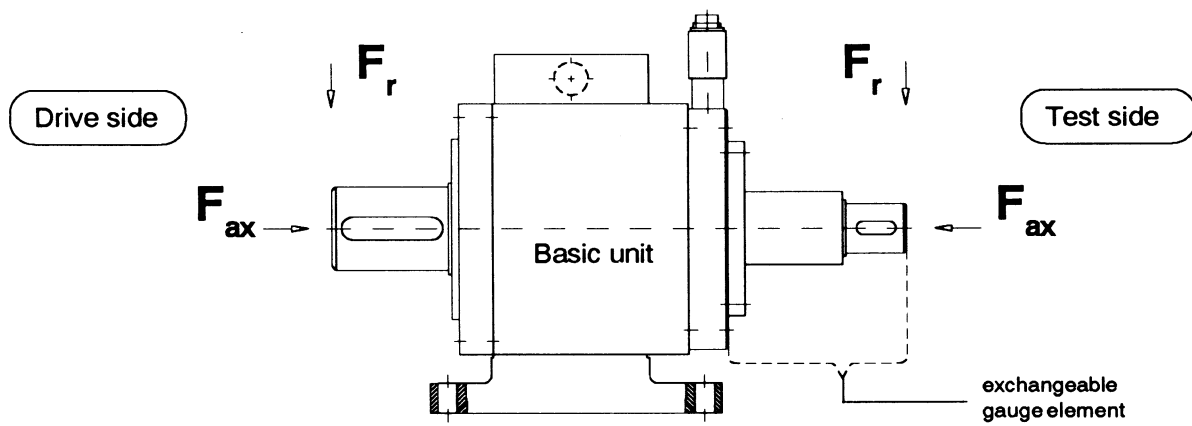

Size	Rated torque in Nm	Speed ²⁾ in rpm	max. mass ³⁾ of half couplings in kg	Test side		Drive side	
				Transverse force F_r in N ¹⁾	Thrust force F_{ax} in N ¹⁾	Transverse force F_r in N ¹⁾	Thrust force F_{ax} in N ¹⁾
01	5	8000	0,15	20	60	200	60
	10		0,25	40			
	20		0,7	80			
	50		1,2	200			
	100		1,8	300			
	200		2,0	300			
02	50	6500	1,6	200	200	800	200
	100		2,5	300			
	200		3,0	300			
	500		4,5	500			
	1000		5,5	600			
03	200	5000	4,0	200	400	1300	400
	500		6,0	450			
	1000		10,0	800			
	2000		14,0	1500			
	5000	3000	40,0	1500			

- 1) Each limit to occur singly only, otherwise errors in accuracy
 2) Maximal speed only with optimal installation conditions
 3) Gravity centre at shaft ends

Volume range and limit values determined by external parts.
 Checking of torsional and natural frequency in bending recommended.

Accessories:

Supply and evaluation unit for torque - see data sheet 4120

Speed testing system - see data sheet 4301

Couplings - see data sheet 8301, 8302, 8303

Test lead for torque transducer (length: 5 m): ordering no. 7195 (other lengths on request)

Test lead for speed transducer (length: 5 m): ordering no. 7207 (other lengths on request)

