



GUEMISA (Electrónica Guerra y Miró Guemisa S.L.)
Sta. Virgilia, 29 - local - 28033 Madrid (Spain)
Tlfn.: (034) 91 764 21 00 Fax.: (034) 91 764 21 32
Email.: ventas@guemisa.com Web.: www.guemisa.com

Dr. Staiger Mohilo

A Kistler Group Company



0125 DF
Torque Measuring
Flange

0225 DF
Dual-range Sensor

The specialist for
test rig technology

Torque measuring flange 0125 DF also available as dual-range sensor 0225 DF

■ Introduction

The **special flange design** of torque sensor 0125 DF makes it very suitable for many test rig applications.

Test bed for engines, dynamometer, wheel load simulation, gear boxes pumps and many others.

■ General

The torque sensor rotor is fixed to the input shaft using a shrink disk arrangement (part of the delivery). The stator is positioned around the rotor and held by a support (part of the delivery).

Output shafts are connected directly to the the measuring side of the sensor. No additional adaptors are necessary.

■ Special features

- Strain gauge principle with non-contact signal transmission
- High accuracy
- Simple excitation, 24 VDC
- ± 5 V output signal of nominal range
- No bearings, maintenance-free
- Short and stiff design
- No additional adaptors needed
- Electronic control of sensor
- Traceable calibration
- CE-certification
- Options:
 - Speed signal (N)
 - ± 10 V output
 - Frequency output (F)
 - Dual-range, ratio 1:10 of nom. range (Type 0225 DF)

■ Examples of application

- Gear box test rigs
- Engine test rigs
- Wheel load simulation
- Calibration can be done using a lever arm with locked loading machine

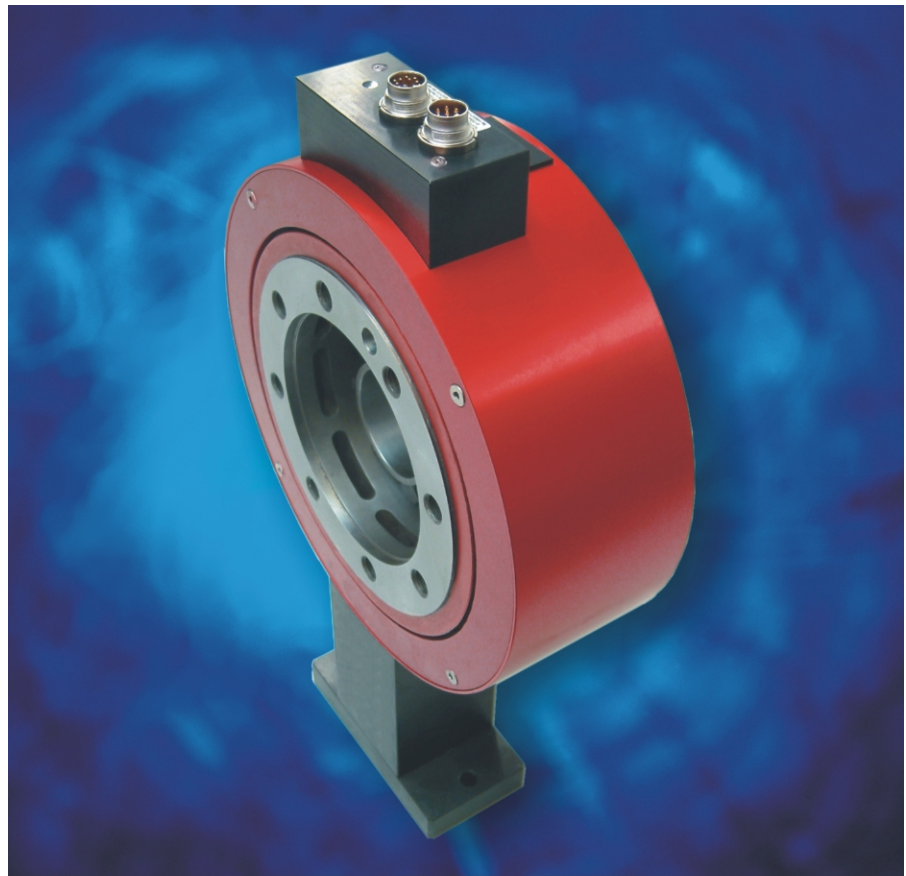

Dual-range torque sensor Type 0225 DF

The new dual-range torque sensors from Dr. Staiger Mohilo have been developed to accurately measure high peak torques as well as medium operating torques using only one sensor.

Examples of a high ratio between peak torque and low operating torques are: start-up torques, abrupt stops, alternating torques, torsional vibrations in combustion engines, compressors, presses, pumps, elevators and other machines.

There is often a lack of knowledge about the effect of unexpected peak torques. For safety, a high range sensor can be selected, but now, the measuring signal in normal operation can be too low.

This is the time to use our dual-range sensor.

It is able to measure and withstand high peak torques as well as low operating torques with good accuracy.

■ Additional advantages of second range

- Inherent overload protection of smaller range because of special design.
- Only one sensor, no additional adaptors are needed.
- Saves handling time.
- Two separately calibrated measuring ranges.

Technical data / Pin assignment

Size	1		2		3		4		
Nominal torque [Nm]:	100	200	500	1,000	1,000	2,000	4,000	10,000	20,000
Permissible max. torque [Nm] (limited by mounting devices):	200	450	1,200	2,000	2,000	4,000	7,000	20,000	40,000
Max. speed [rpm] (balanced by Q = 6,3 degree):	12,000	12,000	9,000	9,000	9,000	9,000	9,000	4,000	4,000
Torsional stiffness (C) [Nm/rad] x 10 ⁶ :	0.2	0.4	1.2	2.6	2.8	4.5	11.0	55.0	90.0
Weight without shrink disk [kg]:	4.2	4.2	6.5	6.8	7.0	7.5	8.0	21.0	21.5
Weight with shrink disk [kg]:	5.1	5.1	7.6	7.9	9.0	9.5	12.2	41.0	47,5
Moment of inertia [kgm ²] incl. shrink disk:	0.011	0.011	0.024	0.026	0.035	0.038	0.046	0.600	0.700
Max. bending torque limit [Nm]:	100	200	500	800	800	1,200	2,000	4,000	-
Max. thrust limit [kN]:	2	4	7	10	10	12	20	31	-
Max. radial limit [kN]:	1	3	6	8	8	15	20	30	-
Part no. with torque analogue output	12494	12561	12630	17670	12729	12733	12763	12736	12784
Part no. with speed measurement	18603	17709	17817	20532	17276	17363	17465	16481	20533

Pin assignment

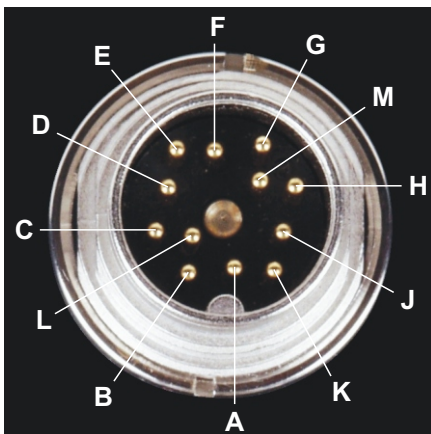

Connection diagram

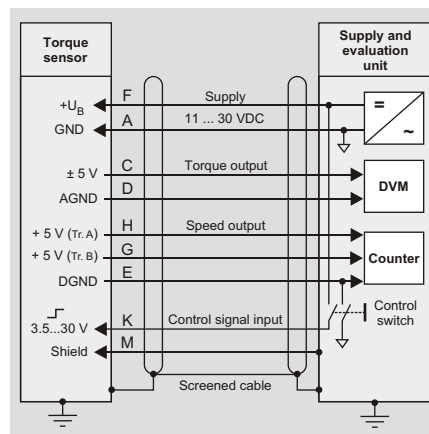

Pin assignment (0225 DF)

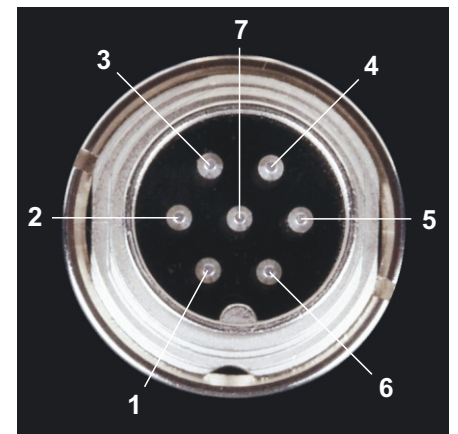

Function	PIN	Description
Supply	F	+U _B +11 V DC ... +30 V DC, power input 2.5 W
	A	GND Related to U _B
Screen	M	In the sensor on housing
Torque output	C	U _A ±5 V / ±10 V at ±M _{Nominal} at > 2 kΩ +5 V / +10 V at control signal activation, R _{i,C} = 10Ω, output short circuit protected to AGND
	D	AGND Related to U _A
Speed pulses	H	Track A Open collector output, internal 1 kΩ resistance to +5 V (pull up), TTL-level
	G	Track B (Tr. B with option 'angle output' only)
	J	Track Z n.c.
100% control input	K	Cont Off: 0 V ... 2 V / On: 3.5 V ... 30 V R _{i,K} = 10 kΩ
Connection to UMV 2000	B	TXD Digital send path to UMV 2000
	L	RXD Digital receive path
Digital ground	E	DGND Related to speed pulses, calibration-/ control input RS-232 connection

PIN	A (Range selection)	C (RS-232 interface)
1	Range activation	n.c.
2	n.c.	n.c.
3	n.c.	DGND
4	n.c.	n.c.
5	n.c.	TXD
6	n.c.	RXD
7	OGND	n.c.

n.c. = not connected

Option A (range selection with optocoupler):

- PIN 1 = 0 (U_{PIN 1,7} = 0 V ... 2 V) normal range (1:1)
- PIN 1 = 1 (U_{PIN 1,7} = 3.5 V ... 30 V) second range (1:10, 1:5)

Option C (RS-232 interface):

- Baudrate 57,600 bps.
- Up to 1,000 measured values per second.

Advices and Applications

Short effective dimensions

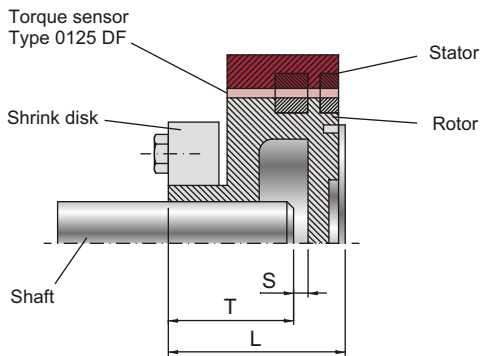

Total length of torque sensor:
 $L - T + S$ (safety)

Example (1.000 Nm):
 $122 - 86 + 2 = 38$ mm only!

Assembly

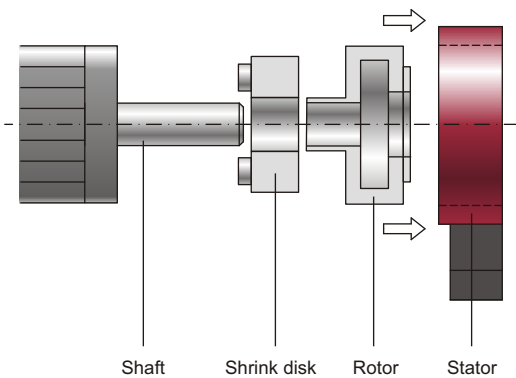

Examples of application

Engine test rig:

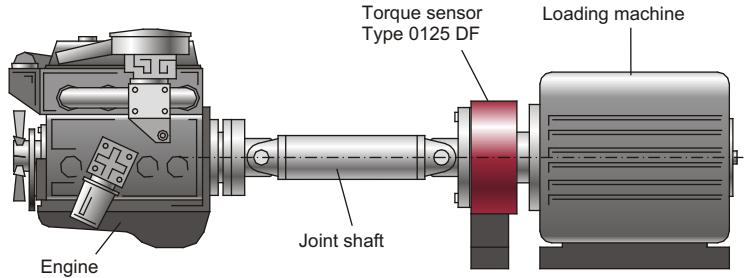

Gear box test bed:

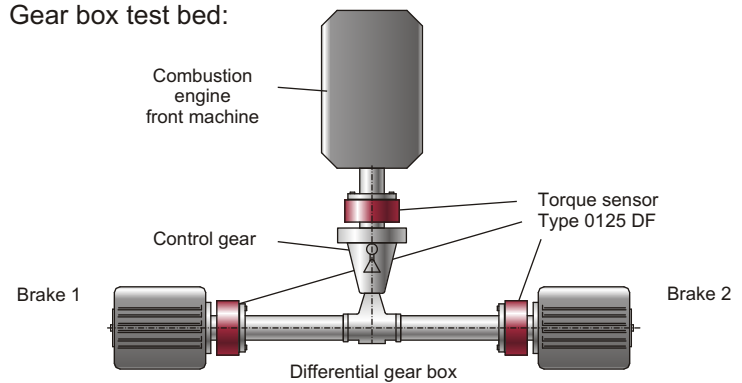

Calibration facility:

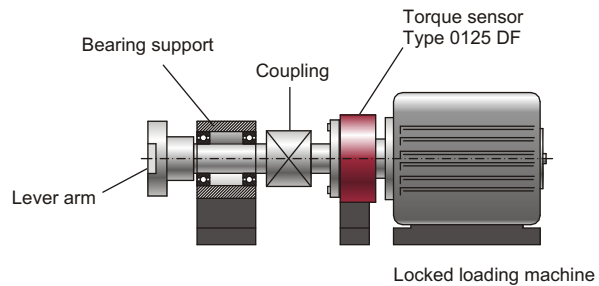

Dimensions

Size 1: 100 Nm; 200 Nm

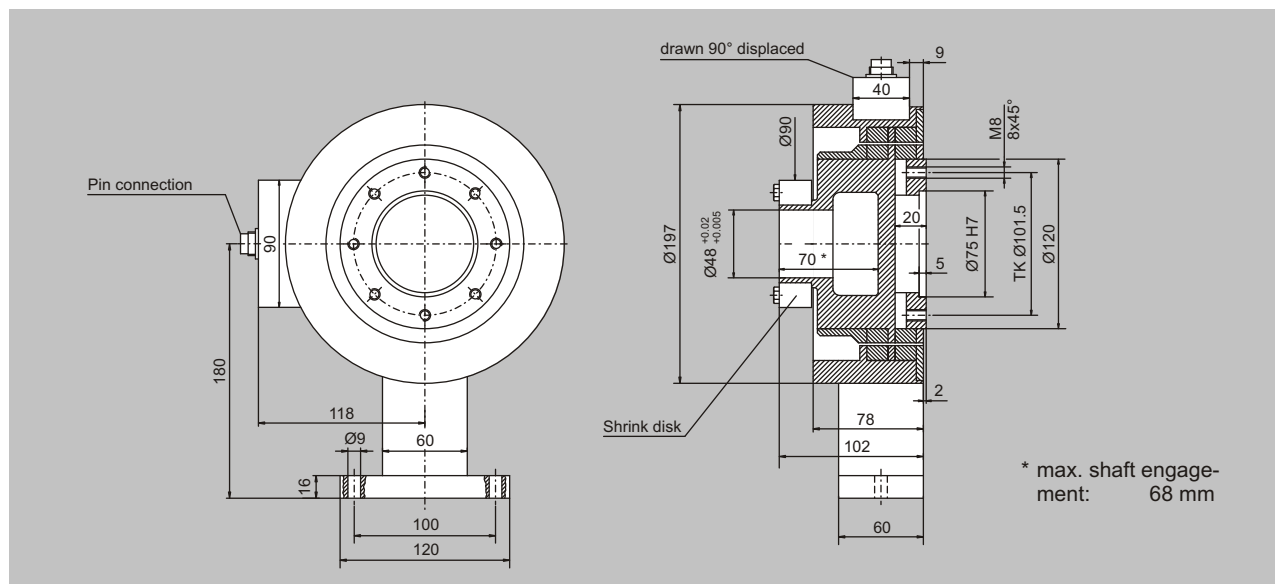

Dimensions

Size 2: 500 Nm; 1,000 Nm

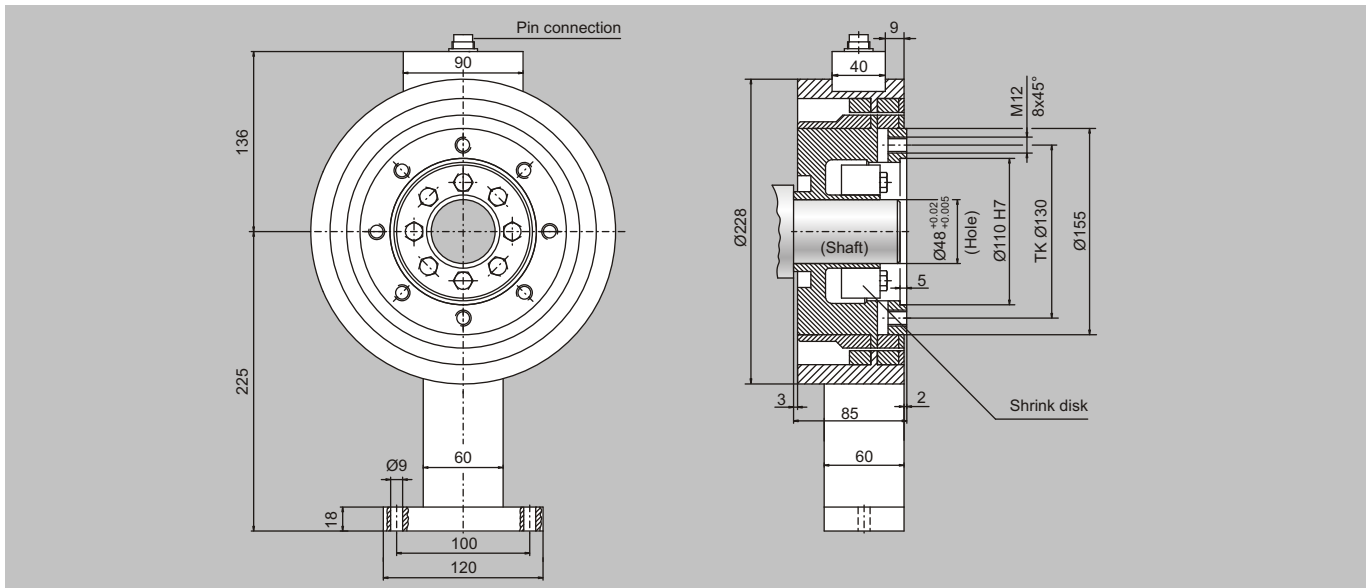

Size 3: 1,000 Nm; 2,000 Nm; 4,000 Nm

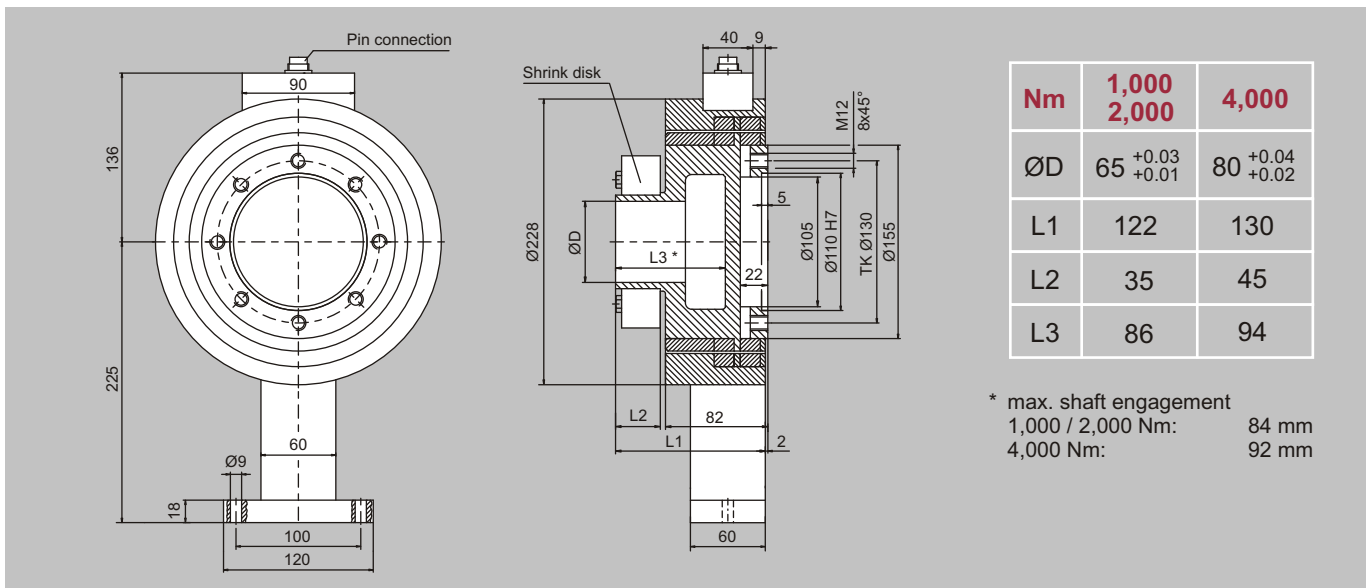

Size 4: 10,000 Nm; 20,000 Nm

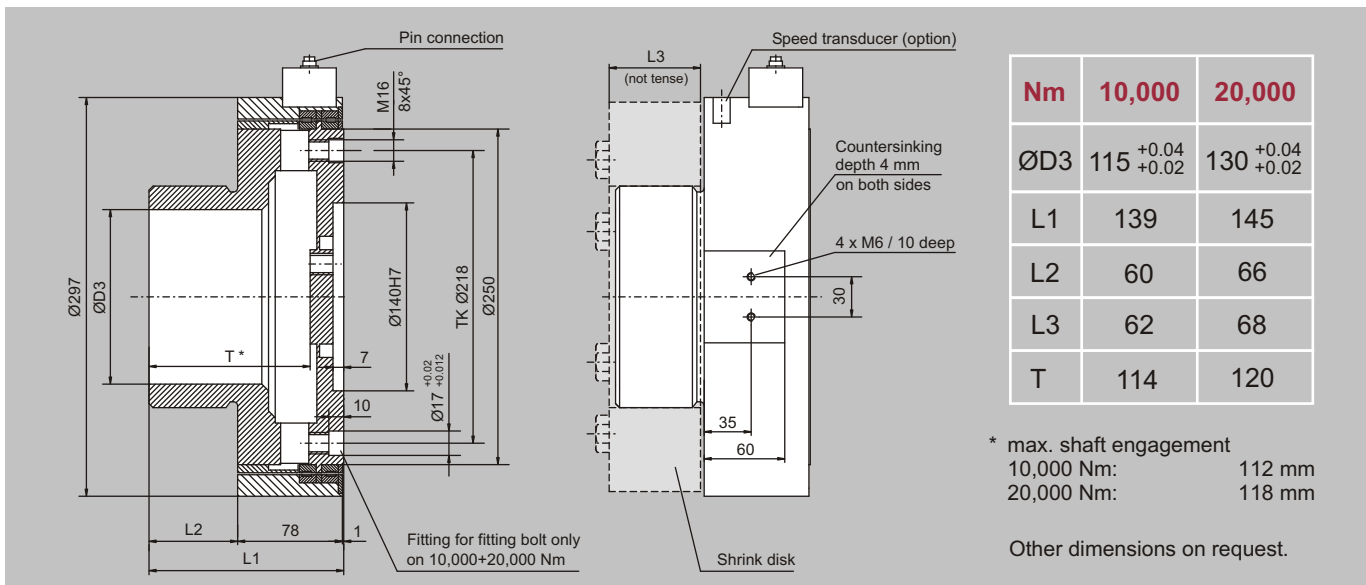

Technical Specifications

■ Mechanical basic data

Overload capacity at operating torque (rupture torque)	2 x rated torque (4 x rated torque)
Max. speed 100; 200 Nm	12,000 rpm
Max. speed 500; 1,000; 2,000; 4,000 Nm	9,000 rpm
Max. speed 10,000; 20,000 Nm	4,000 rpm
Distance rotor to stator	1.5 mm
Flatness tolerance of the connected flange	0.01 mm
Radial eccentricity tolerance of the connected flange	0.02 mm
Protection class (mounted)	IP 54

■ Electronic specifications

Accuracy class < 3,000 Nm (second range, 0225 DF only)	0.1 (0.2)
Accuracy class > 3,000 Nm (second range, 0225 DF only)	0.2 (0.4)
Linearity error including hysteresis:	
related to nominal value	< ± 0.2 %, optional < ± 0.1 % of nom. value
related to second measuring range (0225 DF only)	< ± 0.2 % of nom. value
Repeatability nominal value (second range, 0225 DF only)	< ± 0.1 % (< ± 0.2 %) of nom. value
Ratio of second range (0225 DF only)	1:10
(500 Nm dual-range version is available at the moment, other ranges in preparation)	
Limit frequency -3 dB for voltage output	1 kHz
Voltage output at rated torque	± 5 V DC / optional ± 10 V DC / optional serial output RS 232
Temperature influence on the zero point (1:10 range)	< ± 0.05 % / 10 K (< ± 0.1 % / 10 K) of nom. value
Temperature influence on nominal value (1:10 range)	< ± 0.1 % / 10 K (< ± 0.2 % / 10 K) of nom. value
100 % control input	'ON': 3.5 V ... 30 V / 'OFF': 0 V ... 2 V
Load resistance	> 10 kΩ
Rated temperature range	+10 °C ... +60 °C
Operating temperature range	0 °C ... +70 °C
Shelf temperature range	-25 °C ... +80 °C
Electric connection	12 pin or 7 pin Tuchel built-in plug
Supply voltage	11 V DC ... 30 V DC
Power input	approx. 2.5 W

■ Options

Option A1:	Dual-range sensor, rated torque 1:10
Option B1:	Output signal ± 10 V
Option B2:	Frequency output TTL
Option B3:	Frequency output 24 V
Option B4:	Frequency output push-pull (± 5 V)
Option C:	Increased accuracy
Option D:	RS 232 interface

■ Accessories

- Supply and evaluation unit: VA 3600, acc. data sheet 4160
- Installation-set for easy 19" rack mounting
- Connection cable, length: 5 meters (Part no. 7203)

■ Scope of delivery

- Torque sensor with shrink disk
- Mating connector (Part no. 703)
- Certificate of performance (traceable calibration)
- Manual

■ Example of order specification

0125 DF 2000 - 12733

Torque sensor 0125 DF (nominal torque: 2,000 Nm)

Our torque calibration service offers traceable recalibration of any brands.

Dr. Staiger, Mohilo + Co GmbH

A Kistler Group Company

Maierhofstraße 35

D - 73547 Lorch

Phone +49 · 71 72 · 184 - 0

Fax +49 · 71 72 · 184 - 400

info@staiger-mohilo.de

www.staiger-mohilo.de

www.kistler.com

Example of application:

Engine test rig

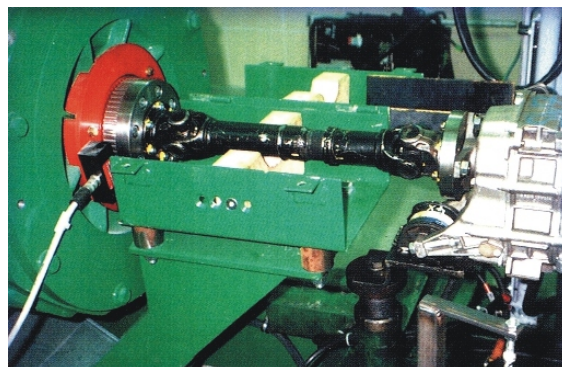

Technical specifications are subject to change.