

Torque Sensor Type IT / Model W

1. Application

Especially designed for small torque readings and high speed applications. The slipringless torque sensor can be used for static and dynamic measurements in both directions. Magnetic speed measurement is as an option available.

The Measurement site of the transducers for a rated torque of up to 2 Nm is not mounted on bearings, thus eliminating measurement error caused by friction.

For special measuring assignments, the design of our torque transducer can be modified to customized requirement.

2. General Information

Torque sensor type 0101.2 IT operate according to the torsional angle measurement principle.

The applications are labs, manufacturing and quality control.



Torque transducer type IT / model W

3. Special features

Nominal range from 0,02 Nm to 20 Nm

Accuracy 0.3 % of full scale

Amplitude-modulated measurement signal is evaluated by special amplifier, model IC 3001 or IC 3002, only

Easy to handle

Optionally available with rotational speed measurement

Integrated overload protection 2 Nm

Robust design

17.06.2004

Torque Sensor
Type IT / model W

0101.2

4. Electrical specification

Linearity deviation:	< ± 0,3% of full scale from 5% up to rated torque
Hysteresis:	< ± 0,2% of full scale
Repeatability span at unchanged mounting position:	< ± 0,1% of full scale
Rated temperature range:	0 ... 65°C
Temperature influence on zero:	< 0,03% / K of full scale
Temp. influ. on characteristics:	< 0,03% / K of full scale
Operating temperature range:	-20°C ... +80°C

5. Technical Data

max. alternating torque:	0,7 x rated torque
Rupture torque:	> 4x rated torque, but at least 5 Nm
test side of torque transducer:	„M“ is engraved
Balancing class acc.to VDI 2060:	Q 2,5
Protection acc.to DIN 40050:	IP 40
Speed sensor (Option)	
Cable terminal speed transducer (Option):	09-0011-09-04 (Binder)

5.1 Technical Data

Rated torque in Nm	Spring rate C in Nm / rad	Speed ¹⁾ in rpm	Moment of inertia in kgm ²		Mass in kg	max. permissible F _r ²⁾ in N	max. permissible F _{ax} ²⁾ in N	Max. permissible torque ²⁾ in Nm
			Drive side	Test side				
0,02	3,1	10000	1,4 x 10 ⁻⁴	2,4 x 10 ⁻⁶	1	3	30	0,02
0,05	7,7	10000	1,4 x 10 ⁻⁴	2,4 x 10 ⁻⁶	1	7	30	0,05
0,1	15,2	10000	1,4 x 10 ⁻⁴	2,4 x 10 ⁻⁶	1	14	30	0,1
0,2	29,4	10000	1,4 x 10 ⁻⁴	2,4 x 10 ⁻⁶	1	30	30	0,2
0,5	70,4	10000	1,4 x 10 ⁻⁴	2,4 x 10 ⁻⁶	1	30	30	0,5
1	130	10000	1,4 x 10 ⁻⁴	2,4 x 10 ⁻⁶	1	30	30	1
2	220	10000	1,4 x 10 ⁻⁴	2,4 x 10 ⁻⁶	1	30	30	2
5	735	10000	7 x 10 ⁻⁵	6 x 10 ⁻⁶	1	40	60	5
10	1280	10000	7 x 10 ⁻⁵	6 x 10 ⁻⁶	1	40	60	10
20	2020	10000	7 x 10 ⁻⁵	6 x 10 ⁻⁶	1	40	60	20

6. Mechanical Dimensions

Rated torque in Nm	Part # with speed sensor	Part # without speed sensor	D1	L1	L2	L3	L4	L5	L6
0,02	10042	5579	8	82	19	74	4	4	29
0,05	10043	5580	8	82	19	74	4	4	29
0,1	10044	5581	8	82	19	74	4	4	29
0,2	10045	5582	8	82	19	74	4	4	29
0,5	10046	5583	8	82	19	74	4	4	29
1	10047	5584	8	82	19	74	4	4	29
2	10048	5585	8	82	19	74	4	4	29
5	10049	5586	12	77	20	64	8	5	17
10	10050	5587	12	77	20	64	8	5	17
20	10051	5588	12	77	20	64	8	5	17

*Beide Wellenenden mit Passfedernuten (2x 180°) nach DIN 6885. Blatt 1

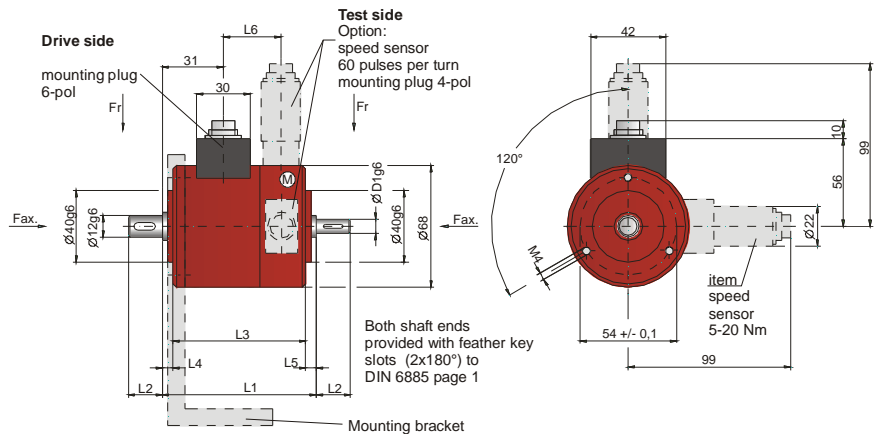

7. Example of order

0101.2 - 0,02 - 10042

data sheet nominal torque part #

Accessories:

-Amplifier (IC3001 or 3002)	data sheet: 4101
-19" Installation kit	data sheet: 7178 und 7181
-Measuring system	data sheet: 4900
-Couplings	data sheet: 8301 and 8303
-Connector lead for torque sensor, length 5m,	part# 7179
- Connector lead for speed sensor, length 5m,	part# 7207
(other length on request)	
-Mounting bracket	data sheet: 8201, part# 10622 (0101.2)

- 1) Max. speed only under optimal installation conditions
- 2) Each limit to occur singly only, otherwise errors in accuracy

0101.2