

GENERAL DESCRIPTION:

MODEL CP-5UY IS A CONTACTLESS POTENTIOMETER WHICH FEATURES LINEAR OUTPUT SIGNAL FOR 300° SHAFT ROTATION. THE UNIT CONSISTS OF A SET OF STATIONARY MAGNETO-RESISTIVE ELEMENT AND PERMANENT MAGNET AND THE ROTATING "SPIRAL YOKE", MIDORI'S PROPRIETARY DESIGN, ATTACHED TO THE SHAFT TO CONVERT WIDE ANGLE MECHANICAL INPUT TO LINEAR ELECTRICAL OUTPUT SIGNAL. ITS PRECISION CONSTRUCTION AND ULTRA RELIABLE OPERATING PERFORMANCE MAKE IT SUITABLE FOR PROCESS CONTROL AND INDUSTRIAL ROBOTIC APPLICATIONS.

ELECTRICAL SPECIFICATIONS:

ELECTRICAL TRAVEL: 300° (F.S.)
 OUTPUT SENSITIVITY: 0.5%Vin/10° MIN.
 INDEPENDENT LINEARITY: ±1% F.S.
 INPUT IMPEDANCE: 30 kOHMS ±30% @Ta=25°C
 INPUT VOLTAGE: 14 Vdc MAX.
 OUTPUT LOAD IMPEDANCE: 10 megOHMS MIN.
 INSULATION RESISTANCE: 100 megOHMS MIN. @500Vdc
 DIELECTRIC STRENGTH: 500 Vrms, 50/60Hz, FOR ONE MINUTE.

MECHANICAL SPECIFICATIONS:

MECHANICAL ANGLE: 360° (ENDLESS)
 TORQUE: 2 gf-cm
 WEIGHT: APPROX. 90 g
 MOUNTING: SERVO MOUNT CLEATS (3 pcs) TO BE SUPPLIED WITH EACH UNIT. REFER TO FIGURE 4 FOR RECOMMENDED PANEL CUTOUT.

ENVIRONMENTAL SPECIFICATIONS:

OPERATING TEMPERATURE: -40°C to +100°C
 STORAGE TEMPERATURE: -40°C to +100°C
 VIBRATION: 7 G's
 SHOCK: 100 G's



GUEMISA
 Sta. Virgilia 3-b ; 1°F 28033 Madrid
 Tfno.: 91 764 21 00 Fax.: 91 764 21 32
 Email: info@guemisa.com

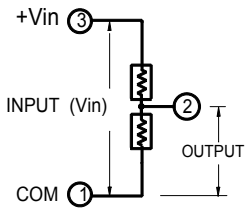

FIGURE 2 SCHEMATIC

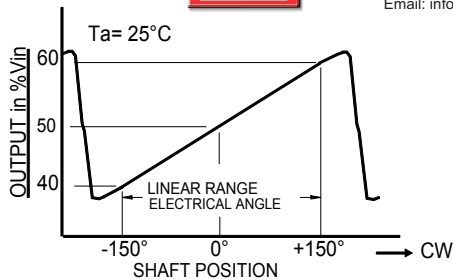

FIGURE 3 TYPICAL OUTPUT CHARACTERISTICS

C.O.N	SYM	DESCRIPTION	DATE	DRAWN	APPR'D

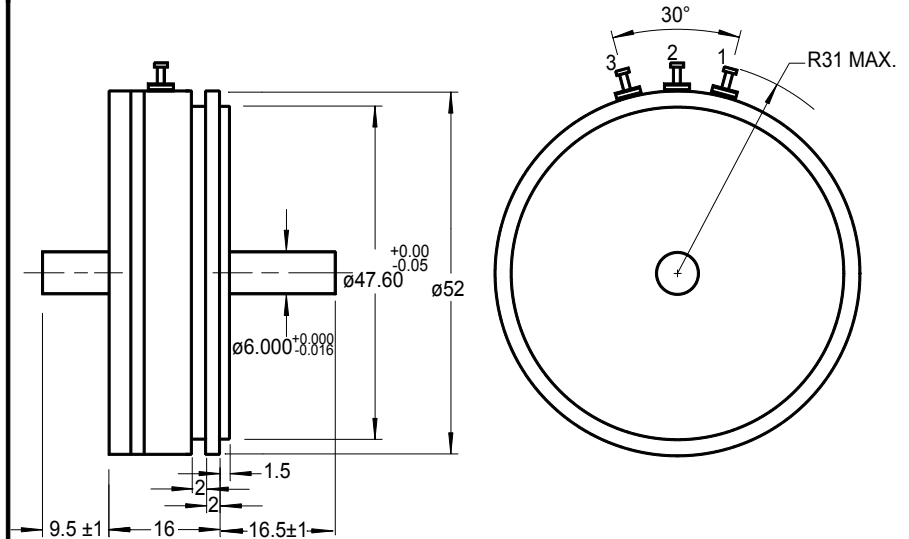

FIGURE 1 OUTLINE DIMENSIONS

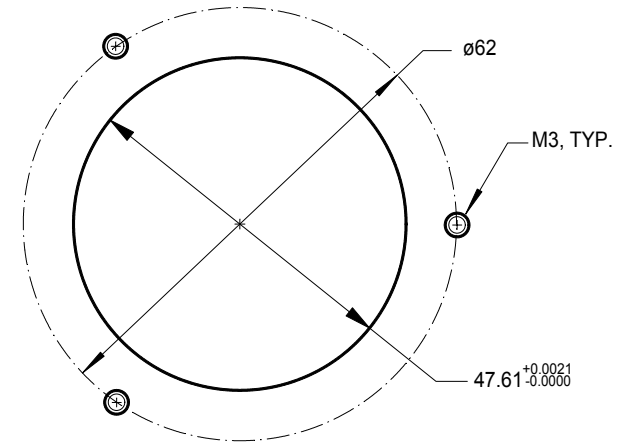

FIGURE 4 PANEL CUTOUT FOR MOUNTING

UNLESS OTHERWISE SPECIFIED DIMENSIONS ARE IN mm(in). TOLERANCES:	DRAWN T. TSUGAWA	DATE 6/4/97	SPECIFICATION DWG FOR MODEL CP-5UY CONTACTLESS POTENTIOMETER 300° ELECTRICAL ANGLE	Midori America Corporation <small>FULLERTON, CA</small>
	CHECKED	DATE		
	APPROVED	DATE		
	APPROVED	DATE		
SCALE:	FILE: CP-5UY	B-MAC-B03		1 OF 1