

# EE80 Series

## HVAC Room Transmitter for CO<sub>2</sub>, Relative Humidity and Temperature

The EE80 series combines CO<sub>2</sub>, relative humidity (RH) and temperature (T) measurement in one housing. The snap-in mounting concept stands for easy installation and replacement within seconds.

EE80 series set new standards in CO<sub>2</sub> measurements for HVAC. The operation is based on the infrared principle. A patented auto-calibration procedure compensates for the aging of the infrared source and ensures outstanding long term stability.

The basic EE80 version for CO<sub>2</sub> and T can be easily extended with a RH plug-in module. The well proven E+E sensor technology guarantees accurate and long term stability.

EE80 provides analogue 0 - 10V voltage outputs.

The optional display indicates sequentially the actual measuring data.



EE80

### Typical Applications

building management for residential and office areas  
ventilation control

### Features

CO<sub>2</sub> / RH / T measurement in one device  
RH output with plug-in module  
easiest installation  
modern design  
long term stability  
optional display

### Technical Data

#### Measuring values

##### CO<sub>2</sub>

Measurement principle	Non-Dispersive Infrared Technology (NDIR)	
Sensor	E+E Dual Source Infrared System	
Working range	0 - 2000 ppm	
Accuracy at 20 degC (68°F)	< ± (50 ppm +2% of measure value)	
Response time $t_{63}$	< 90 sec	
Temperature dependence	typ. 5 ppm CO <sub>2</sub> /degC	
Long term stability	typ. 20 ppm / year	
Sample rate	ca. 0.5 min	

##### Relative Humidity

Measurement principle	capacitive	
Sensor element	HC103	
Working range <sup>1)</sup>	10...90% RH	
Accuracy at 20 degC (68°F)	±3% RH (30...70% RH)	±5% (10...90% RH)

##### Temperature

Accuracy at 20 degC (68°F)	±0.3 degC (±0.54°F)	
----------------------------	---------------------	--

#### Outputs

0...2000 ppm / 0...100% RH /	0 - 5V	-1mA < I <sub>L</sub> < 1mA
0...50 degC (32...122°F)	0 - 10V	-1mA < I <sub>L</sub> < 1mA

#### General

Supply voltage SELV	24V AC ±20%	15 - 35V DC	SELV = Safety Extra Low Voltage
Power requirement	< 3 W		
Warm up time <sup>2)</sup>	< 5 min		

Display	LC display: alternating CO <sub>2</sub> (ppm) / T (°C or °F) / RH (% RH)
Electrical connection	screw terminals max. 1.5 mm <sup>2</sup> (AWG16)
Electromagnetic compatibility	EN 50081-1 EN 50082-2
Working temperature range	0...90% RH (non condensing) / -5...55 degC (23...131°F)
Storage temperature range	0...90% RH (non condensing) / -20...60 degC (-4...140°F)



1) refer to the working range of the humidity sensor HC103!  
 2) warm up time for performance according specification

## Connection Diagram

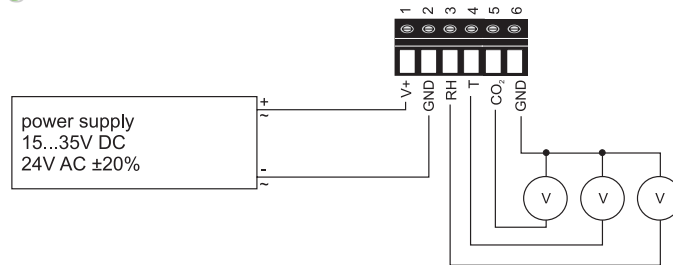

## Housing Dimensions (mm)

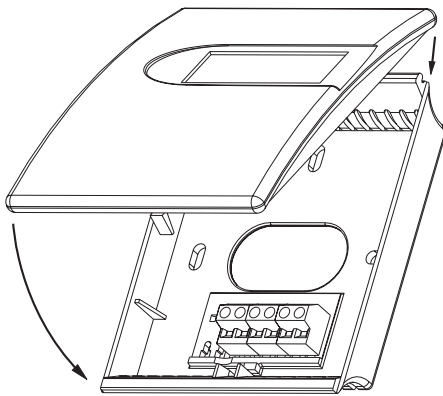

W x H x D = 85 x 100 x 26mm  
 (3.3 x 3.9 x 1 inch)

Material of housing: PC  
 Protection class: IP20

Colour of housing: Cover: RAL 9003 (signal white)  
 Back: RAL 7035 (light grey)

(other colours upon request)

## Order Example

### EE80-2CT3D04

Working range: 0...2000 ppm  
 Model: CO<sub>2</sub> + Temperature  
 Output: 0-10V  
 Display: with display  
 T-Unit: °C  
 T-Scale: 0...50 degC (32...122°F)

## Ordering Guide

WORKING RANGE	MODEL	OUTPUT	DISPLAY	T-UNIT	T-SCALE
0...2000 ppm (2)	CO <sub>2</sub> + T (CT) CO <sub>2</sub> + T + RH (CTF)	0-5V (2) 0-10V (3)	without display (-) with display (D04)	°C (-) °F (E01)	standard (0...50degC) (-) (32...122°F) other T-scaling refer to page 11 (Txx)
<b>EE80-</b>					

## Accessories

- humidity plug-in module (HA011003)



Sta. Virgilia 29 Local.1A 28033 Madrid  
 Tfno.: 91 764 21 00 Fax.: 91 764 21 32  
 www.guemisa.com Email.: info@guemisa.com