

EE10 Series

HVAC Humidity and Temperature Transmitter for Indoor Applications

EE10 room transmitters are the ideal solution for indoor applications such as HVAC in residential and official buildings.

The very stylish, functional housing makes easy installation and fast exchange of the sensing unit for service purposes possible. The high quality E+E humidity sensor and state-of-the-art microprocessor controlled electronics are the guarantee for best accuracy and a wide range of options.

The standard humidity output of EE10 transmitters is 4 - 20 mA or 0 - 10 V. The temperature output signal can be active or passive.

All EE10 versions can be equipped with a good legible LC display. For EE10-FT versions the displayed values for humidity and temperature will alternate.



Typical Applications

building management for residential and office areas
air conditioning
switching cabinets
climate control in hotels and museums

Features

excellent price / performance ratio
easiest installation
modern design
long term stable
optional display

Technical Data

Measuring Quantities

Relative Humidity

Humidity sensor	HC103	
Analogue output 0...100 %r.H.	0-10 V	-1 mA < I _L < 1mA
	4-20 mA (two wires)	R _L < (U _v -10)/0.02 < 500 Ohm
Working range ¹⁾	0...95 % RH	
Accuracy at 20°C (68°F) and U _v =24VDC	±2% RH (40...60% RH)	±3% RH (10...90% RH)
Temperature influence at 60% RH	typical 0.06% RH / °C (0.03% RH / °F)	

Temperature (active output)

Analogue output 0...50°C (32...122°F) ²⁾	0-10 V	-1 mA < I _L < 1mA
	4-20 mA (two wires)	R _L < (U _v -10)/0.02 < 500 Ohm
Accuracy at 20°C (68°F) and U _v =24VDC	FT3: ±0.25°C (±0.45°F)	FT6: ±0.4°C (±0.72°F)

Temperature (passive output)

Type of T-Sensor	please see ordering guide
------------------	---------------------------

General Data

Voltage supply (U _v)	for 0 - 10 V	15 - 40 VDC or 24 VAC ±20%
	for 4 - 20 mA	28V DC > U _v > 10 + 0.02 x R _L (R _L < 500 Ohm)
Current consumption	for DC supply:	typical 4 mA
	for AC supply:	typical 15 mA _{eff}
Electrical connection	screw terminals max. 1.5 mm ² (AWG 16)	
Display	for EE10-FTx version	Humidity / Temperature alternating
	for EE10-Fx and EE10-FPx version	Humidity
CE compatibility according	EN 50081-1	FCC Part15 ClassB
	EN 50082-1	ICES-003 ClassB
Temperature ranges	working temperature range:	-5...55°C (23...131°F)
	working temperature with display:	-5...55°C (23...131°F)
	storage temperature range:	-25...60°C (-13...140°F)



1) Please refer to the working range of the HC103

2) Other T-scaling refer to page 11

Connection Diagram

EE10-FT3

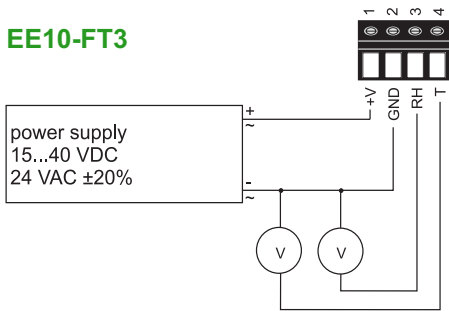

EE10-F3 EE10-FP3

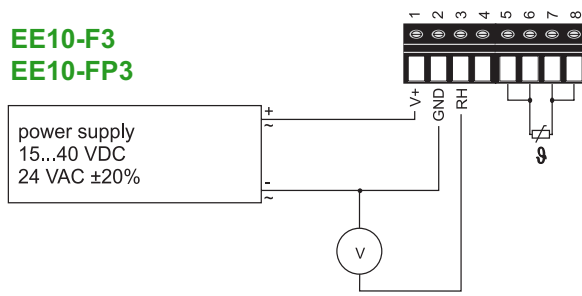

EE10-FT6

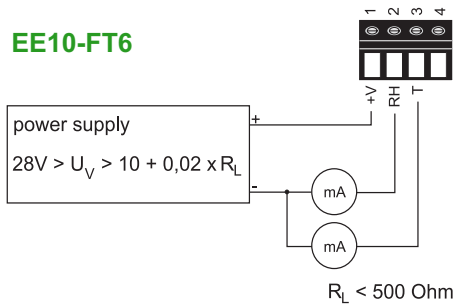

EE10-F6 EE10-FP6

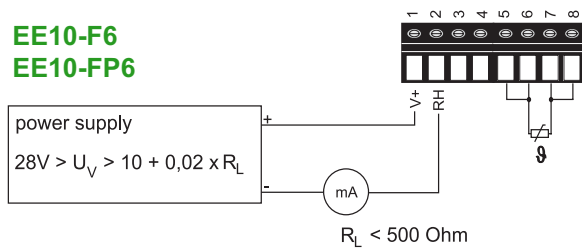

Dimensions (mm)

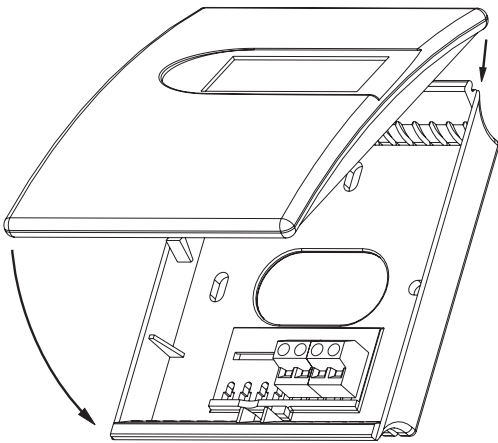

W x H x D = 85 x 100 x 26mm
 (3.3 x 3.9 x 1 inch)

Housing: PC
 Protection class: IP20

Housing colour: Cover: RAL 9003 (signal white)
 Back: RAL 7035 (light grey)

(other colours upon request)

Order Example

EE10-FP6D-D04

Model: Humidity +
 Temperature Transmitter
 with passive T-output

Output humidity: 4-20mA
 Output temperature: Pt 1000 DIN B
 Display: with Display
 T-Unit: °C
 T-Scale: 0...50°C

Ordering Guide

MODEL	OUTPUT	T-SENSOR (only passive)	DISPLAY	T - UNIT (only for (D04))	T-SCALE (only for FT)
humidity + temperature	(FT) 0-10V (3)	Pt 100 DIN A (A)	without display (-)	°C (-)	standard (0...50°C) (-)
humidity	(F) 4-20 mA (6)	Pt 100 DIN B (B)	with display (D04)	°F (E01)	(32...122°F)
humidity + temperature passive	(FP)	Pt 1000 DIN A (C) Pt 1000 DIN B (D)			other T-scaling see page 11
EE10-					